No.	E2EB-3354
ISSUED:	JUL. 1, 2010
REVISED:	APR. 22, 2011

SERVICE INFORMATION



**HOSHIZAKI
CRESCENT CUBER**

**MODEL FM-170EE-HC(N)
FM-170EE-50-HC(N)**

**PARTS LIST
(HE)**

K-1 JUL. 2010

AUXILIARY CODE

U - 1

The auxiliary code is the first two characters in the serial number. The first character indicates the production year. Years progress or regress in alphabetical order. The series of letters and skipped letters depend on UL listing, production, and model. See the auxiliary code(s) and corresponding year(s) on the front cover.

The second character indicates significant part changes within the same year. Base is "1" and this number advances for each change. If there is no significant part change at the turn of the year, this number starts from "0."

MARKS LOCATED UNDER THE AUXILIARY CODE

- = Part deleted.
- x = Part deleted and replaced by "o" part.
- o = New part in place of "x" part.

FASTENER PART NUMBER

SCREWS

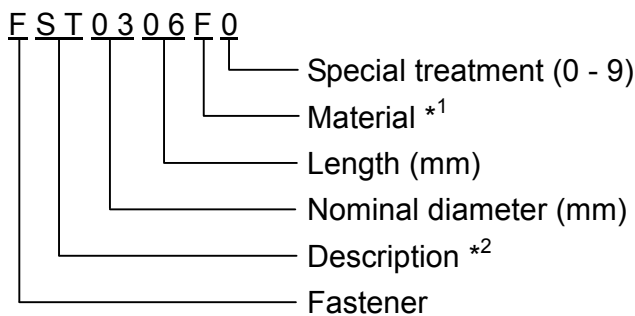

*¹ Material

- F: Steel
- S: Austenitic stainless steel
- M: Martensitic stainless steel
- B: Copper alloy
- P: Polycarbonate
- N: Polyamide
- V: PVC
- A: ABS
- X: Polyacetal
- L: Aluminum

NUTS & WASHERS

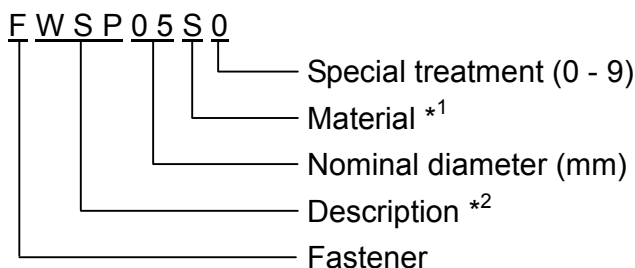

*² Description

- First letter
- S: Machine screw
- T: Tapping screw
- M: Wood screw
- B: Bolt
- W: Washer
- N: Nut

FM-170EE-HC, FM-170EE-HCN

FM-170EE-50-HC,

FM-170EE-50-HCN

A. ICE FLAKER ASSY(1/2)

(K-1) and later

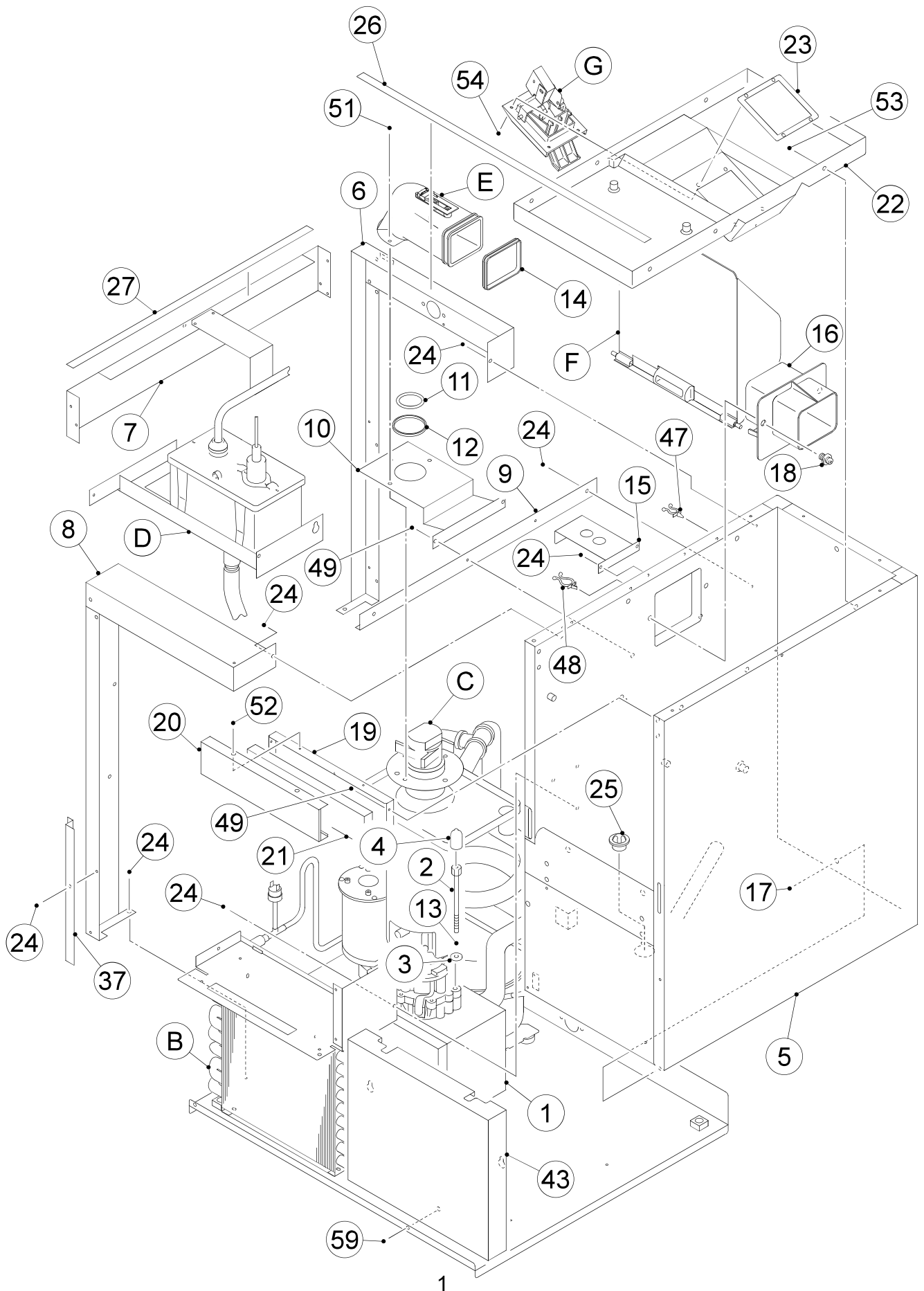

FM-170EE-HC, FM-170EE-HCN

FM-170EE-50-HC,

FM-170EE-50-HCN

A. ICE FLAKER ASSY(2/2)

(K-1) and later

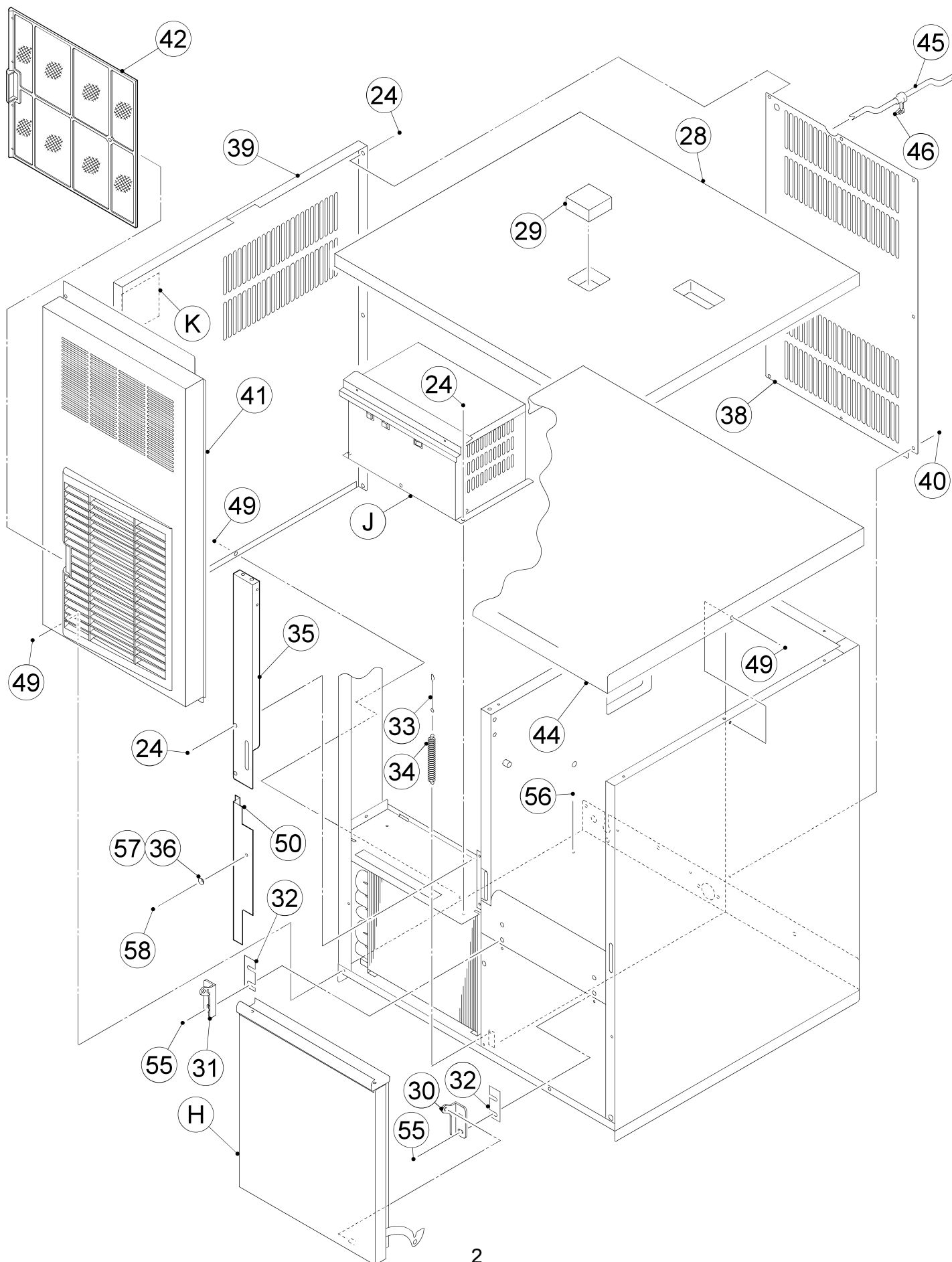

HE

MODEL: FM-170EE-HC(N) FM-170EE-50-HC(N)		TITLE: A. ICE FLAKER ASSY					
INDEX NO.	DESCRIPTION	MATERIAL OR MODEL NUMBER	PART NUMBER	REQ'D NUMBER			
				K-1			
B	REFRIGERATION CIRCUIT	FM-170EE-HC(N)	120879A01	1			
		FM-170EE-50-HC(N)	120879001	1			
C	ICE MAKING UNIT	FM-170EE-HC	358938003	1			
		FM-170EE-50-HC					
		FM-170EE-HCN	358938004	1			
	FM-170EE-50-HCN						
D	WATER CIRCUIT		115737A01	1			
E	SPOUT ASSY		358941A01	1			
F	SLOPE (ASSY)	FM-170EE-HC(N)	362588G01	1			
		FM-170EE-50-HC(N)	362590G01	1			
G	BIN SWITCH ASSY		310810A01	1			
H	DOOR ASSY	FM-170EE-HC(N)	373745A01	1			
		FM-170EE-50-HC(N)	373748A01	1			
J	CONTROL BOX ASSY		245052A02	1			
K	LABEL LOCATION		258937A01	1			
P	ACCESSORIES		ACCE2EB-2	1			
1	GEAR MOTOR BASE		241751G01	1			
2	SCREW - M8		458298-03	3			
3	SEAL WASHER		458299-01	3			
4	VINYL CAP		451272-01	3			
5	BIN-FOAMED	FM-170EE-HC(N)	115726G01	1			
		FM-170EE-50-HC(N)	115727G01	1			
6	REAR FRAME		245370-01	1			
7	SIDE FRAME		362978-01	1			
8	FRONT FRAME(L)		245372-01	1			
9	BRACE - EVAPORATOR		466287-01	1			
10	BRACKET - EVA		358886-01	1			
11	O RING		7616-G045	1			

HE

MODEL: FM-170EE-HC(N) FM-170EE-50-HC(N)		TITLE: A. ICE FLAKER ASSY					
INDEX NO.	DESCRIPTION	MATERIAL OR MODEL NUMBER	PART NUMBER	REQ'D NUMBER			
				K-1			
12	RING		432661-03	1			
13	SPRIT LOCK WASHER		FWSP08S0	3			
14	PACKING(A)		427152-02	1			
15	SWITCH LEVER		466286-01	1			
16	SPOUT(B)		232654-02	1			
17	HEX HEAD BOLT SW		FBK0512S0	1			
18	BOLT		462612-01	2			
19	FRONT BRACE - BIN	FM-170EE-HC(N)	466313-01	1			
20	FRONT FRAME - BIN	FM-170EE-HC(N)	466312-01	1			
		FM-170EE-50-HC(N)	466310-01	1			
21	INSULATION - FRONT	FM-170EE-HC(N)	418332-01	1			
		FM-170EE-50-HC(N)	466394-02	1			
22	UPPER PANEL - BIN	FM-170EE-HC(N)	241746-01	1			
		FM-170EE-50-HC(N)	241750-01	1			
23	FRAME - BIN SWITCH		466617-01	1			
24	TRUSS HEAD SCREW		FST0408F0	17			
25	DRAIN PIPE - CUT		466275-01	1			
26	SOFT TAPE	FM-170EE-HC(N)	115588-43	2			
		FM-170EE-50-HC(N)	115588Z01	2			
27	SOFT TAPE		115588-44	3			
28	INSULATION (A) - TOP	FM-170EE-HC(N)	358885-01	1			
		FM-170EE-50-HC(N)	358885-02	1			
29	INSULATION (B) - TOP		466314-01	1			
30	HINGE (RIGHT)		4H0456-01	1			
31	HINGE (LEFT)		426053-01	1			
32	HINGE SPACER (B)		4H0605-02	2			
33	HOOK (H)		404060-07	1			
34	SPRING	FM-170EE-HC(N)	4H0491-01	1			
		FM-170EE-50-HC(N)	4H0823-01	1			
35	FRONT PLATE		358898-01	1			

HE

MODEL: FM-170EE-HC(N) FM-170EE-50-HC(N)		TITLE: A. ICE FLAKER ASSY					
INDEX NO.	DESCRIPTION	MATERIAL OR MODEL NUMBER	PART NUMBER	REQ'D NUMBER			
				K-1			
36	TAPER COLLAR		4H0171-01	2			
37	BARRIER - AIR		466295-01	1			
38	REAR PANEL (L)		245047-01	1			
39	SIDE PANEL(L)		245044-01	1			
40	S-TITE TRUSS HEAD SCREW		FTS0408M0	13			
41	FRONT PANEL		249060G01	1			
42	AIR FILTER (B)		2A2063G01	1			
43	FRONT PANEL (R)	FM-170EE-HC(N)	362595-01	1			
		FM-170EE-50-HC(N)	362596-01	1			
44	TOP PANEL	FM-170EE-HC(N)	241759-01	1			
		FM-170EE-50-HC(N)	241759-02	1			
45	POWER CORD		452263-01	1			
46	BUSHING		448949-01	1			
47	CLAMP	No.249	427902-03	5			
48	CLAMP	No.4253	427902-05	4			
49	TRUSS HEAD SCREW		FST0408S0	9			
50	BARRIER - AIR(B)		468195-01	1			
51	HEX HEAD BOLT SW		FBK0412S0	3			
52	T2 SCREW		FT20408S0	2			
53	T2 SCREW	FM-170EE-HC(N)	FT20410S0	9			
		FM-170EE-50-HC(N)	FT20410S0	11			
54	FLAT HEAD SCREW		FSF0412S0	4			
55	HEX HEAD BOLT SW		FBK0616S0	4			
56	PAN HEAD SCREW SW		FSK0408S0	1			
57	FLAT WASHER		FWPL04F0	1			
58	POP RIVET	SSD43BS	7170-0003	1			
59	TRUSS HEAD SCREW		FST0410S0	1			

FM-170EE-HC, FM-170EE-HCN

FM-170EE-50-HC,

FM-170EE-50-HCN

B. REFRIGERATION CIRCUIT

(K-1) and later

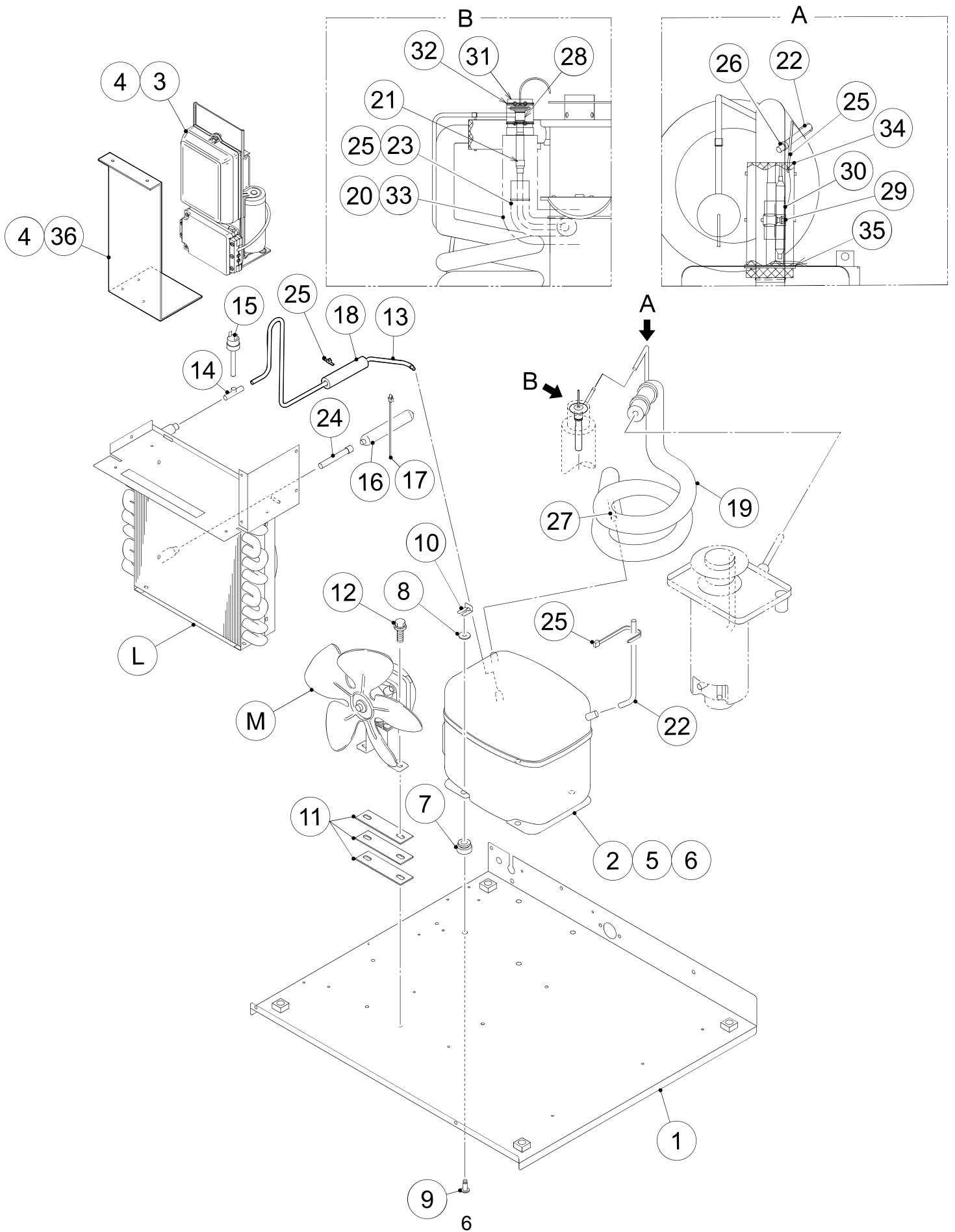

HE

MODEL: FM-170EE-HC(N) FM-170EE-50-HC(N)				TITLE: B. REFRIGERATION CIRCUIT			
INDEX NO.	DESCRIPTION	MATERIAL OR MODEL NUMBER	PART NUMBER	REQ'D NUMBER			
				K-1			
L	CONDENSER ASSY		241780A01	1			
M	FAN MOTOR ASSY		3H9446A01	1			
1	BASE	FM-170EE-HC(N)	245046G01	1			
		FM-170EE-50-HC(N)	245048G01	1			
2	COMPRESSOR		P01934-01	1			
3	STARTING DEVICE		P01935-01	1			
4	TRUSS HEAD SCREW(FT)		FTS0408M0	7			
5	CORD RELIEF		452239-01	1			
6	COVER		459924-01	1			
7	RUBBER GROMMET		4A1452-01	4			
8	WASHER		450894-01	4			
9	STEEL PIN		452255-01	4			
10	CLIP		452256-01	4			
11	SPACER		466281-01	3			
12	HEX.BOLT SW		458660-01	2			
13	COPPER TUBE(A)-HIGH SIDE		358893-01	1			
14	TEE		420041-03	1			
15	PRESSURE SWITCH	R290	459868-05	1			
16	DRIER		458776-01	1			
17	TIE		457167-01	1			
18	INSULATION TUBE	7762-1020 L=90	H71020090	1			
19	HEAT EXCHANGER		258933G01	1			
20	TIE	CV-200	7920-0010	2			
21	REDUCER		421904-17	1			
22	PROCESS TUBE - LOW SIDE		466291-01	1			
23	INSULATION TUBE		H71030300	1			
24	CHARGE TUBE		469826-01	1			
25	TIE	CV-150	7920-0003	13			
26	LOCKRING STOPPER		P01677-01	1			

HE

MODEL: FM-170EE-HC(N) FM-170EE-50-HC(N)		TITLE: B. REFRIGERATION CIRCUIT					
INDEX NO.	DESCRIPTION	MATERIAL OR MODEL NUMBER	PART NUMBER	REQ'D NUMBER			
				K-1			
27	RUBBER SHEET		446470-01	1			
28	EXPANSION VALVE		P01933-01	1			
29	HOLDER-EXP.VALVE		451267-01	1			
30	CLAMP		443461-01	1			
31	VALVE COVER		3Y3196P01	1			
32	CLAMP		P00752-01	2			
33	INSULATION TUBE		H73858B28	1			
34	INSULATION TUBE		H73858B15	1			
35	TIE	CV-300	7920-0028	2			
36	BRACKET/DEVICE		475073M01	1			

FM-170EE-HC, FM-170EE-HCN

FM-170EE-50-HC,

FM-170EE-50-HCN

C. ICE MAKING UNIT

(K-1) and later

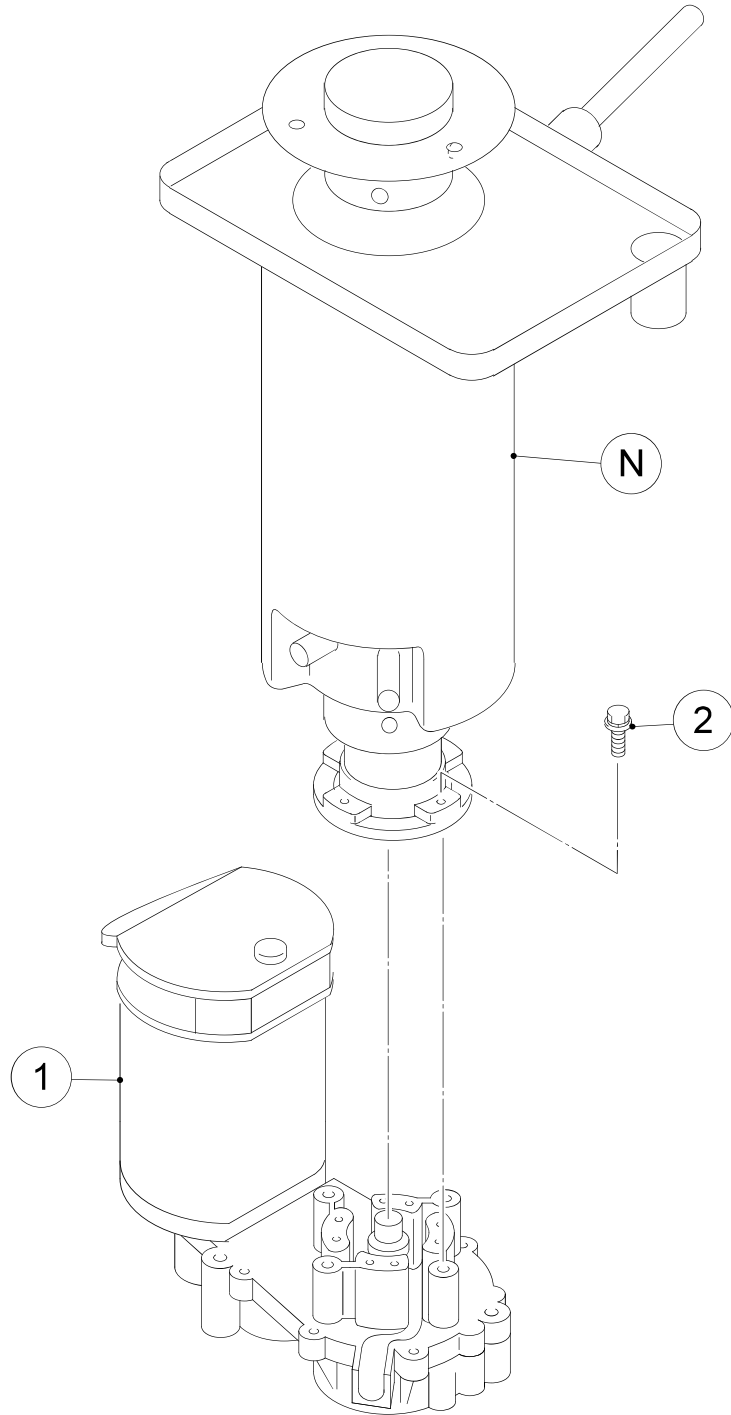

FM-170EE-HC, FM-170EE-HCN
FM-170EE-50-HC,
FM-170EE-50-HCN

D. WATER CIRCUIT

(K-1) and later

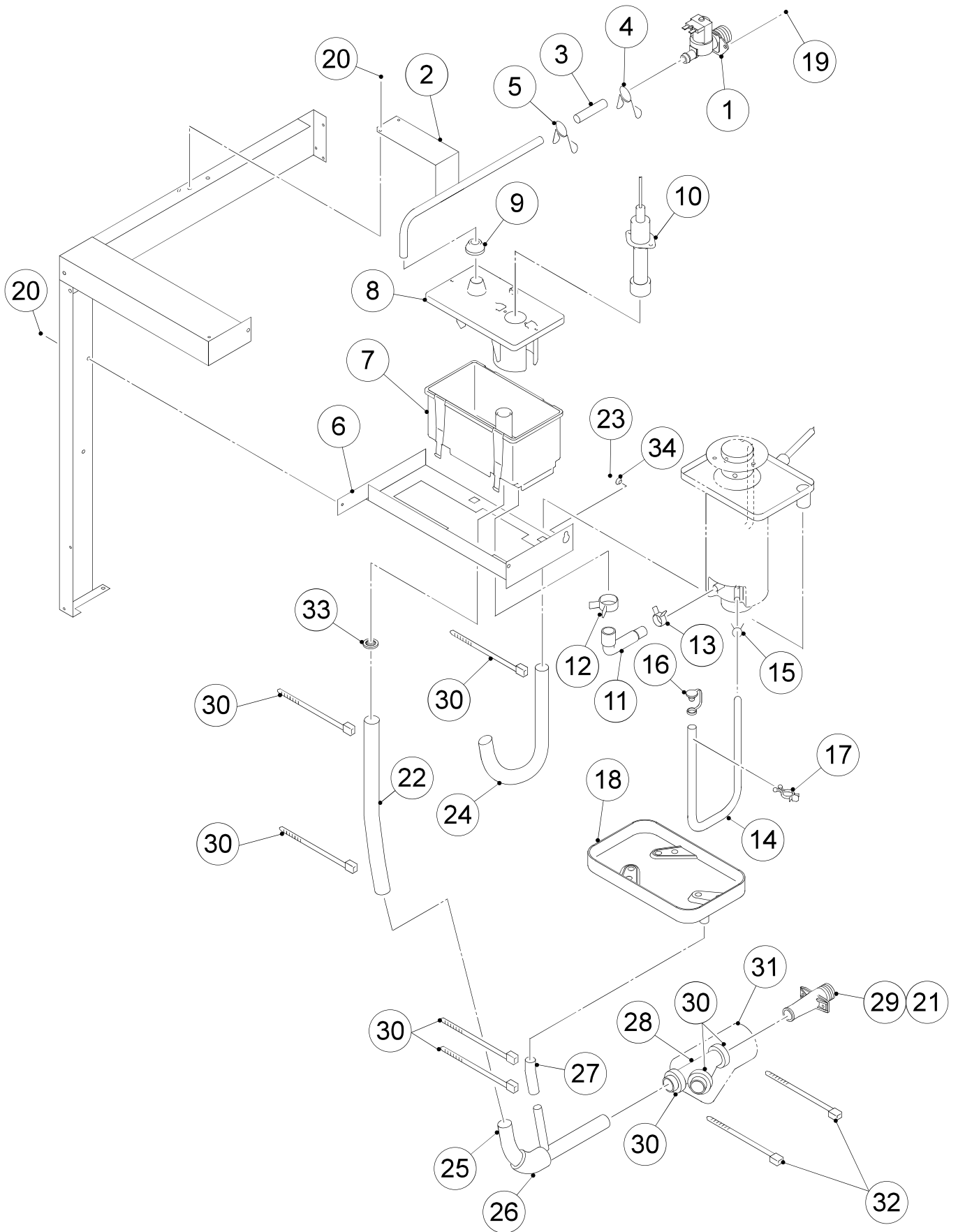

HE

MODEL: FM-170EE-HC(N) FM-170EE-50-HC(N)		TITLE: D. WATER CIRCUIT ASSY					
INDEX NO.	DESCRIPTION	MATERIAL OR MODEL NUMBER	PART NUMBER	REQ'D NUMBER			
				K-1			
1	WATER VALVE		452993-01	1			
2	WATER SUPPLY PIPE		358887G01	1			
3	SILICONE HOSE		115737-05	1			
4	HOSE CLAMP		435934-03	1			
5	HOSE CLAMP		435934-02	1			
6	RESERVOIR BRACKET		362979-01	1			
7	RESERVOIR		232626-01	1			
8	RESERVOIR COVER		232627-01	1			
9	COVER RESERVOIR INLET		415094-01	1			
10	FLOAT SWITCH		458279-01	1			
11	HOSE		458308-01	1			
12	CLIP BAND		423866-08	1			
13	CLIP BAND		423866-04	1			
14	SOFT PVC HOSE		115737-17	1			
15	HOSE CLAMP		435934-01	1			
16	CAP		431689-01	1			
17	CLAMP	No.249	427902-03	1			
18	DRAIN PAN		318155-01	1			
19	HEX HEAD BOLT		FBH0408S0	2			
20	TRUSS HEAD SCREW		FST0408F0	4			
21	T2 SCREW		FT20410S0	2			
22	VINYL HOSE		115737-22	1			
23	POP RIVET	SSD43BS	7170-0003	1			
24	VINYL HOSE		115737-23	1			
25	DRAIN PIPE(A)		466285G01	1			
26	INSULATION TUBE		115737-25	1			
27	VINYL HOSE		115737-26	1			
28	DRAIN JOINT		358882-01	1			
29	DRAIN PIPE		321035-01	1			
30	CABLE TIE	CV-150	7920-0003	8			

HE

MODEL: FM-170EE-HC(N) FM-170EE-50-HC(N)		TITLE: D. WATER CIRCUIT ASSY					
INDEX NO.	DESCRIPTION	MATERIAL OR MODEL NUMBER	PART NUMBER	REQ'D NUMBER			
				K-1			
31	INSULATION TUBE		115737-31	1			
32	CABLE TIE	CV-200	7920-0010	2			
33	FILTER		4X1497G01	1			
34	TAPER COLLAR		4H0171-01	1			

FM-170EE-HC, FM-170EE-HCN

FM-170EE-50-HC,

FM-170EE-50-HCN

E. SPOUT ASSY

(K-1) and later

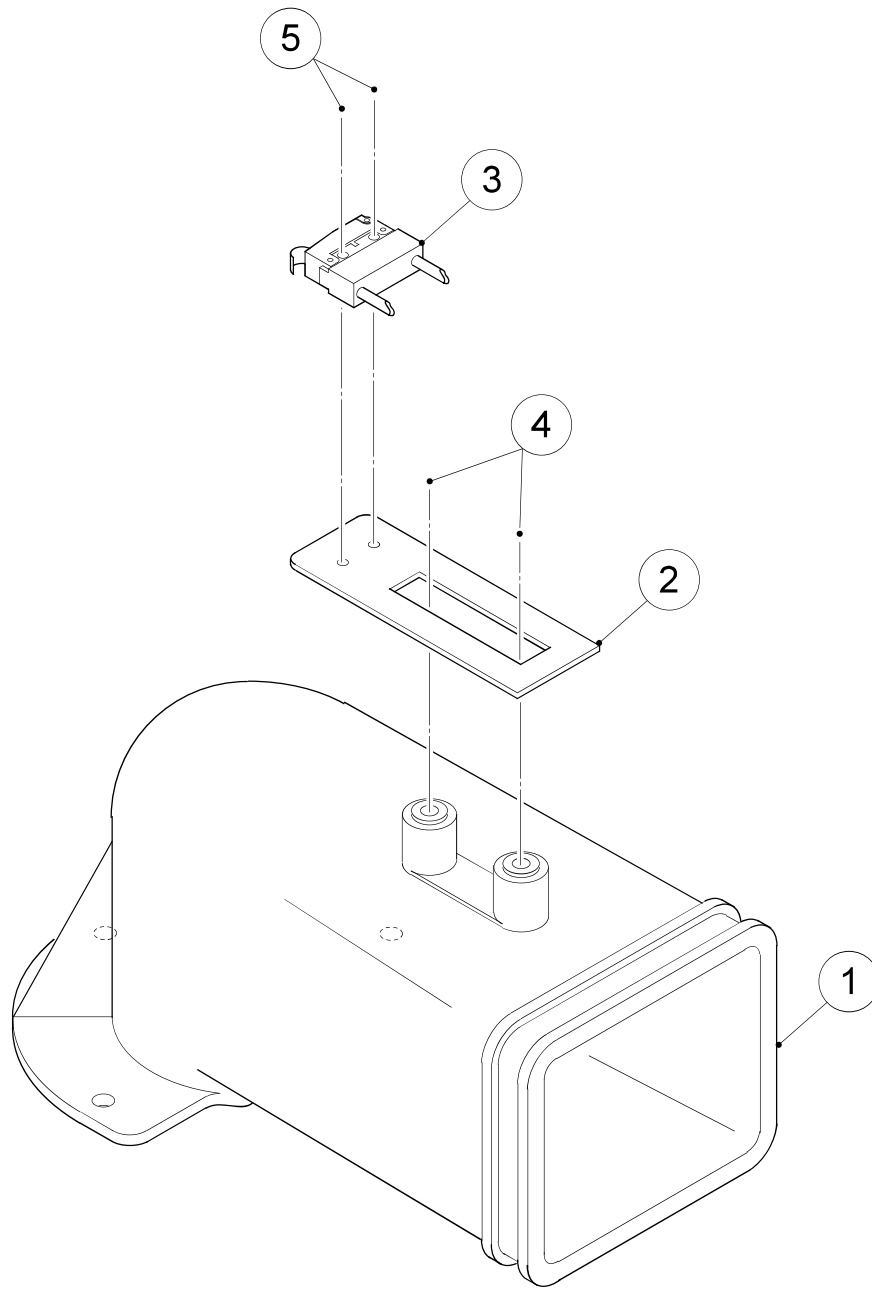

FM-170EE-HC, FM-170EE-HCN
FM-170EE-50-HC,
FM-170EE-50-HCN

F. SLOPE ASSY

(K-1) and later

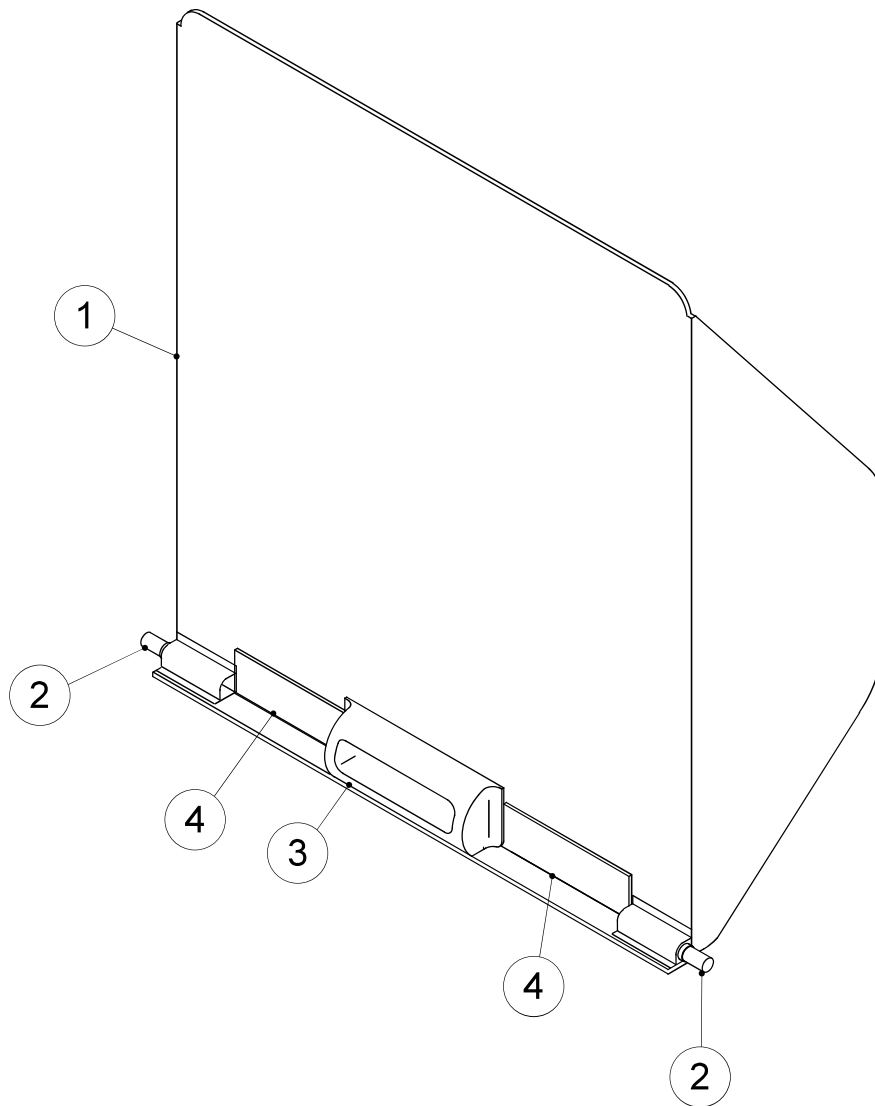

FM-170EE-HC, FM-170EE-HCN

FM-170EE-50-HC,

FM-170EE-50-HCN

G. BIN SWITCH ASSY

(K-1) and later

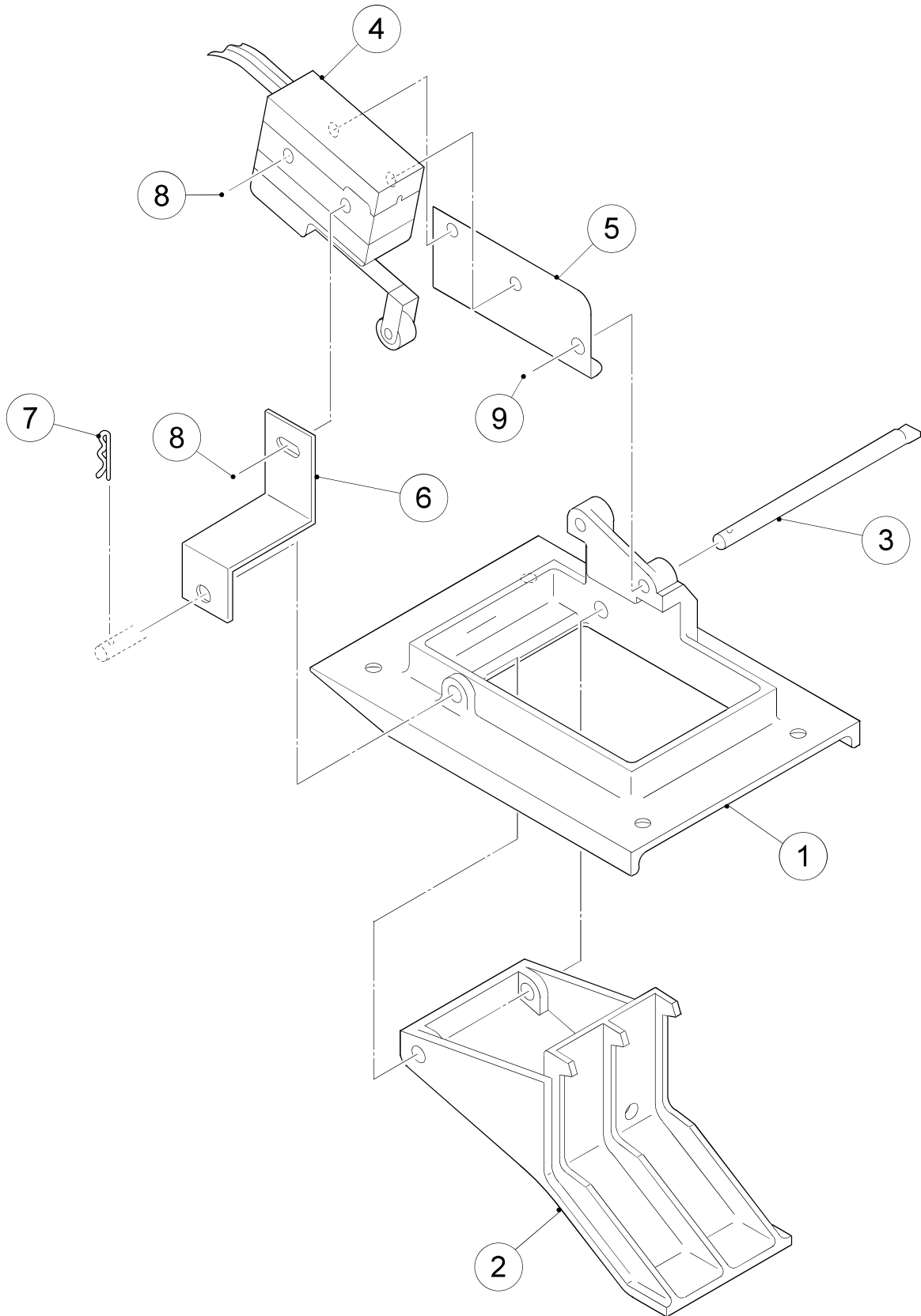

FM-170EE-HC, FM-170EE-HCN

FM-170EE-50-HC,

FM-170EE-50-HCN

H. DOOR ASSY

(K-1) and later

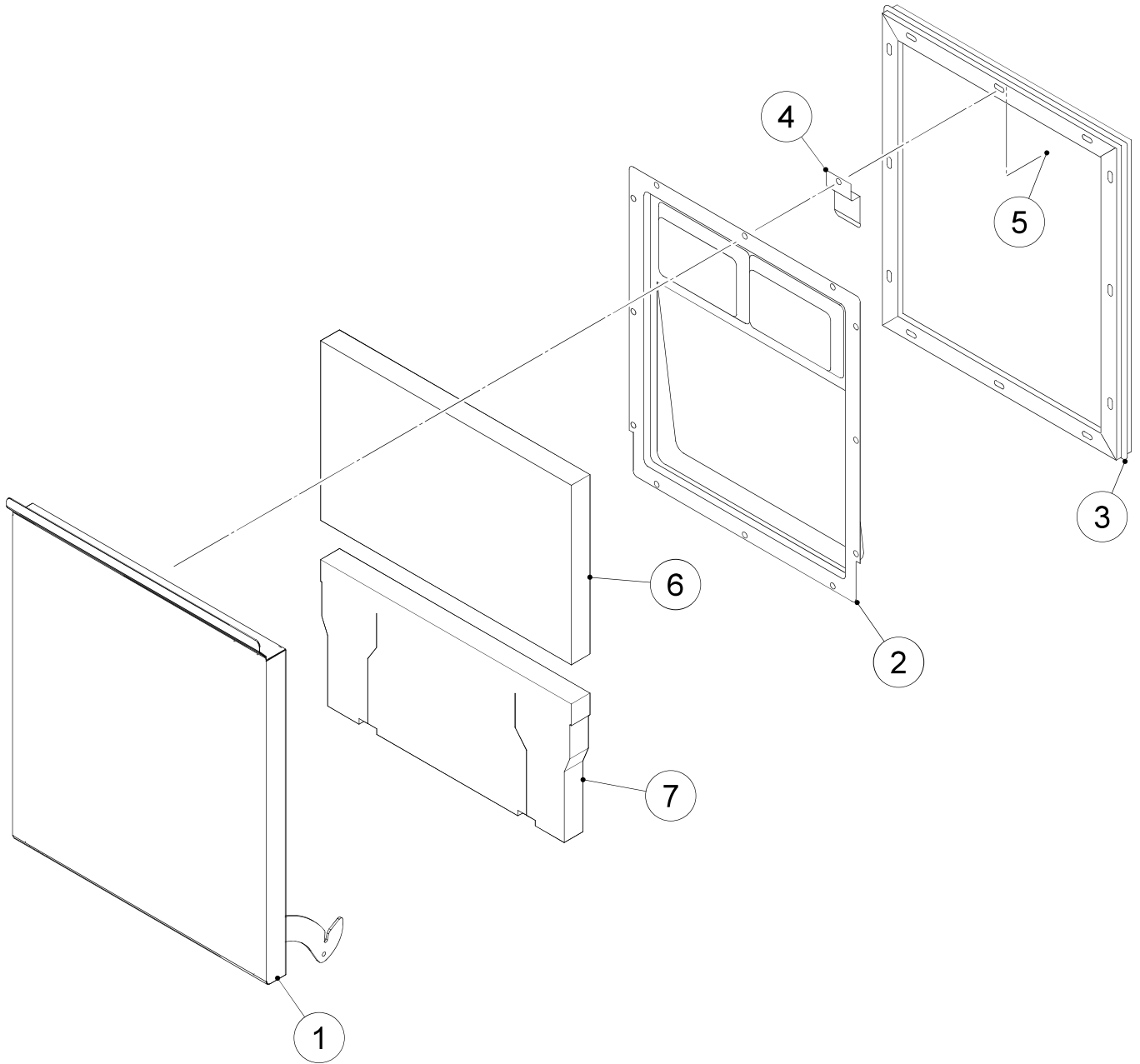

FM-170EE-HC, FM-170EE-HCN

FM-170EE-50-HC,

FM-170EE-50-HCN

J. CONTROL BOX ASSY

(K-1) and later

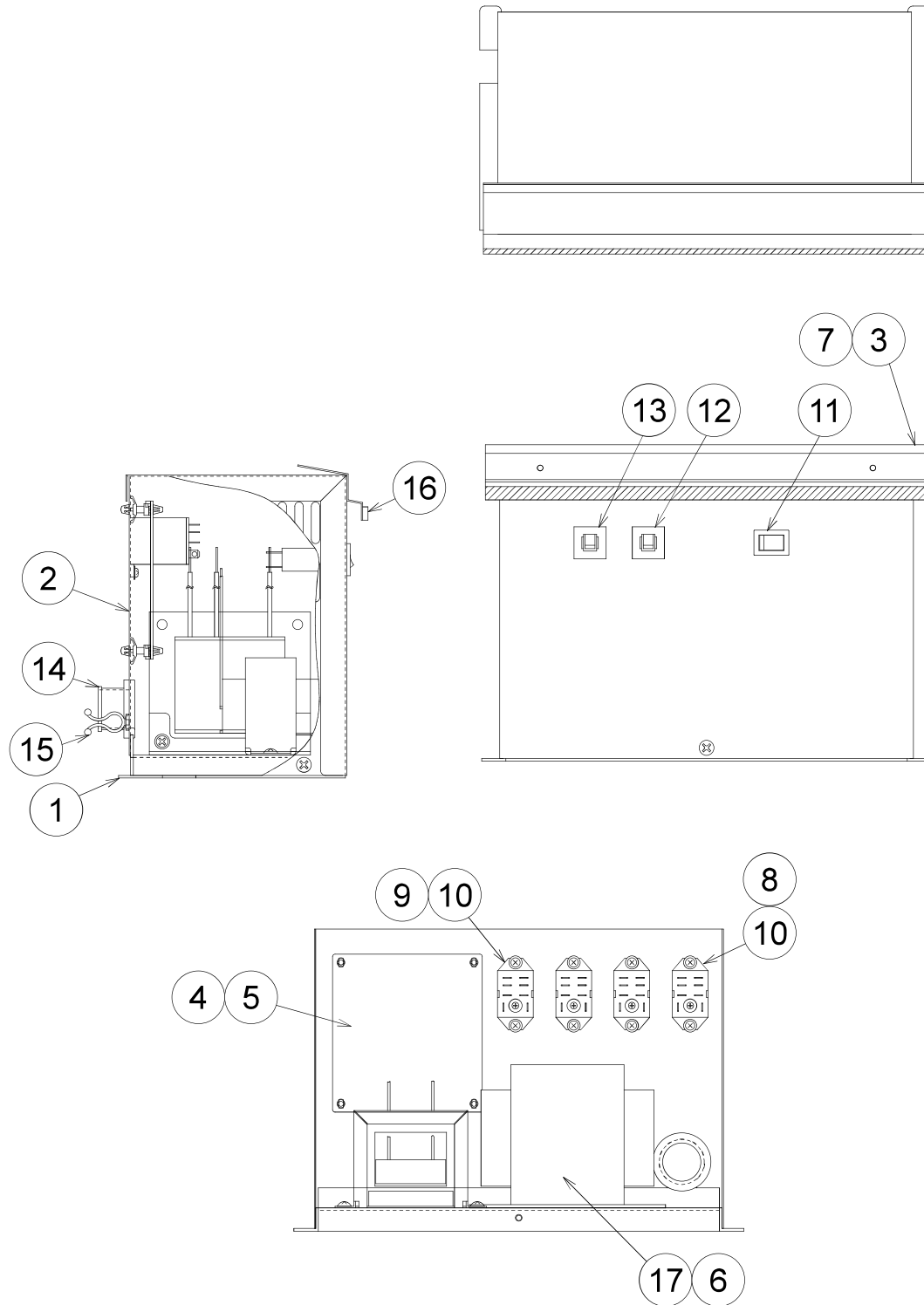

FM-170EE-HC, FM-170EE-HCN
 FM-170EE-50-HC,
 FM-170EE-50-HCN

K. LABEL LOCATION

(K-1) and later

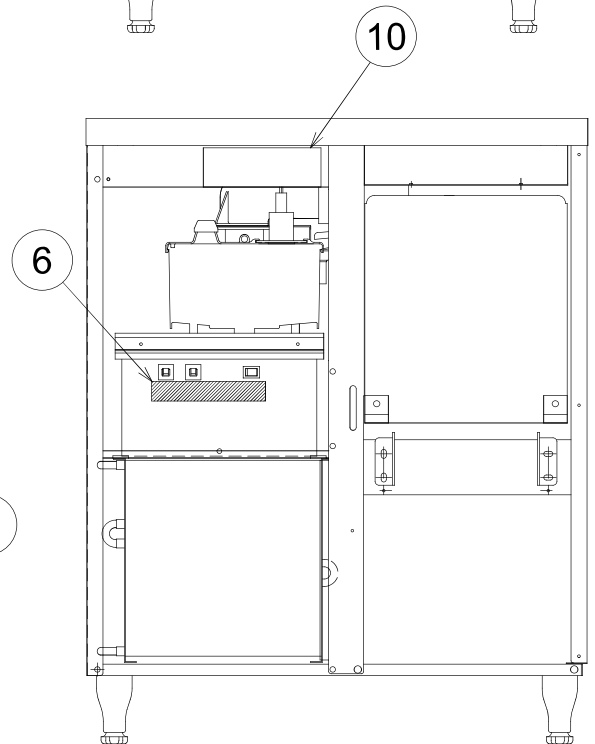
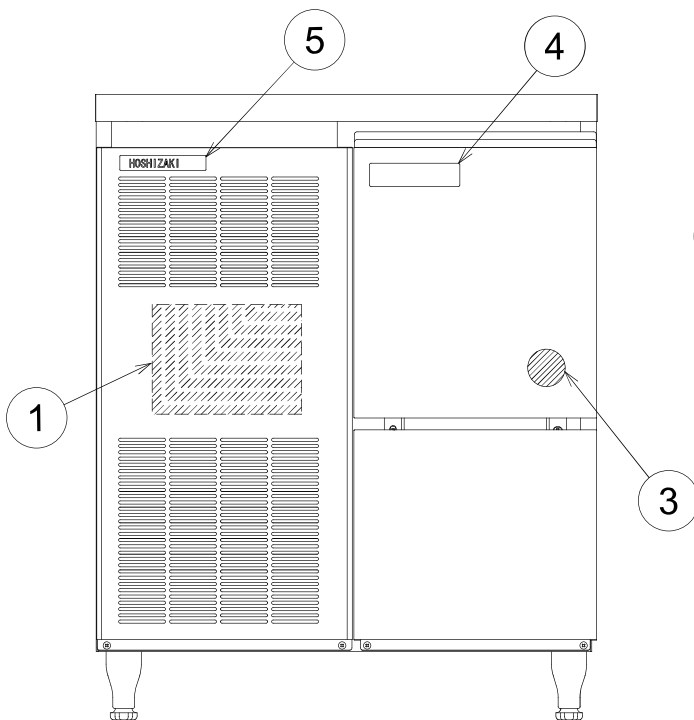
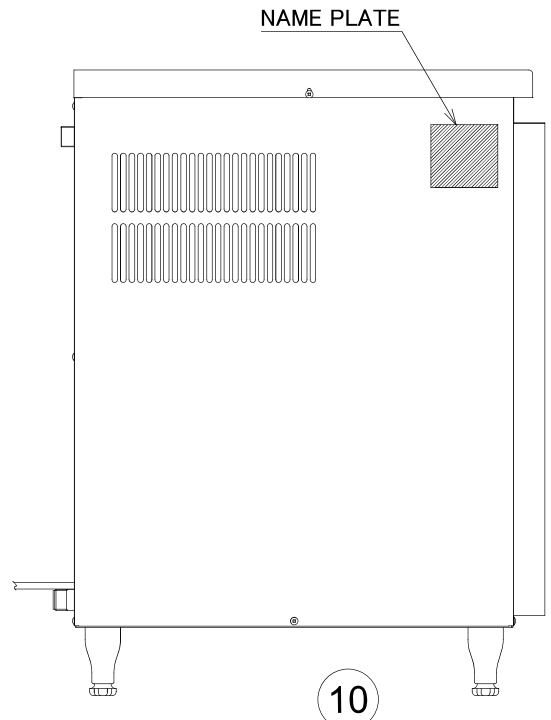
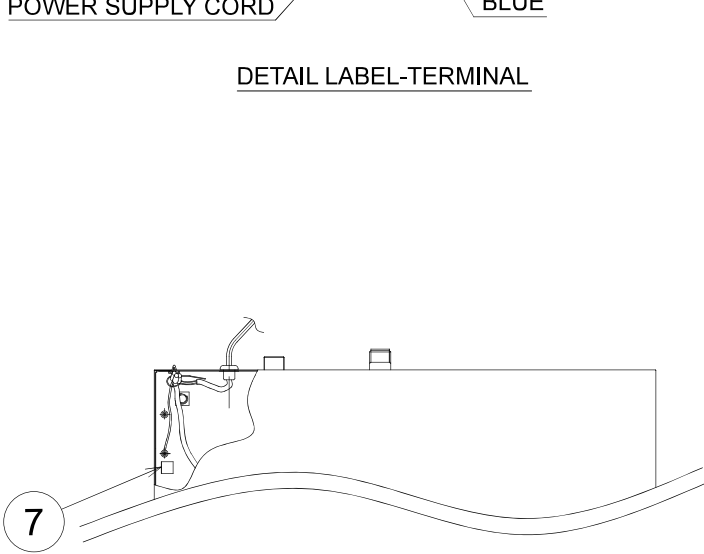
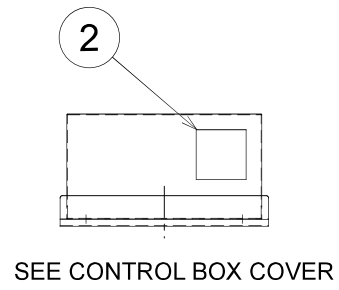
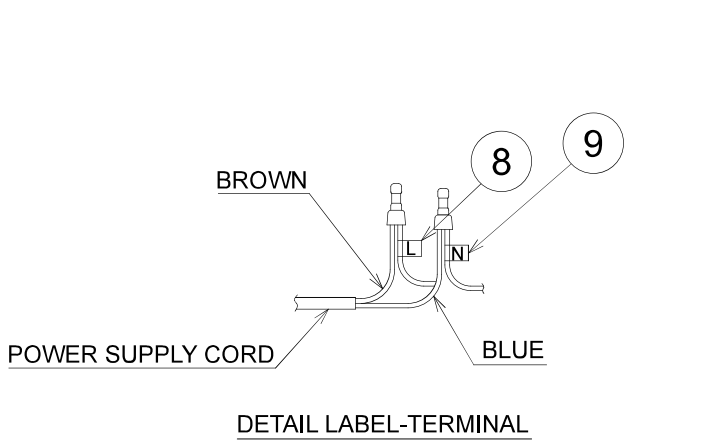

FM-170EE-HC, FM-170EE-HCN

FM-170EE-50-HC,

FM-170EE-50-HCN

L. CONDENSER ASSY

(K-1) and later

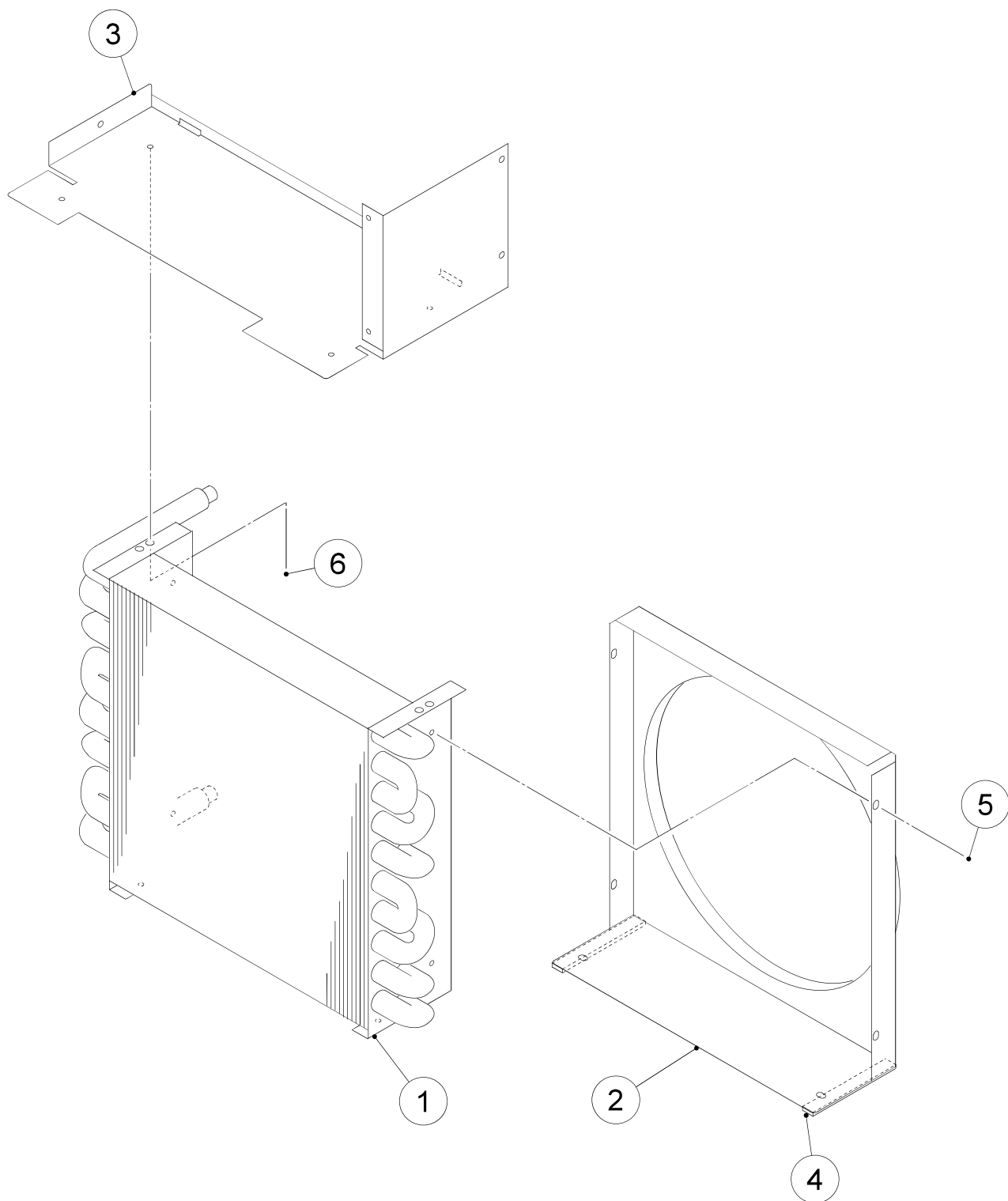

(S-0950)

FM-170EE-HC, FM-170EE-HCN

FM-170EE-50-HC,

FM-170EE-50-HCN

M. FAN MOTOR ASSY

(K-1) and later

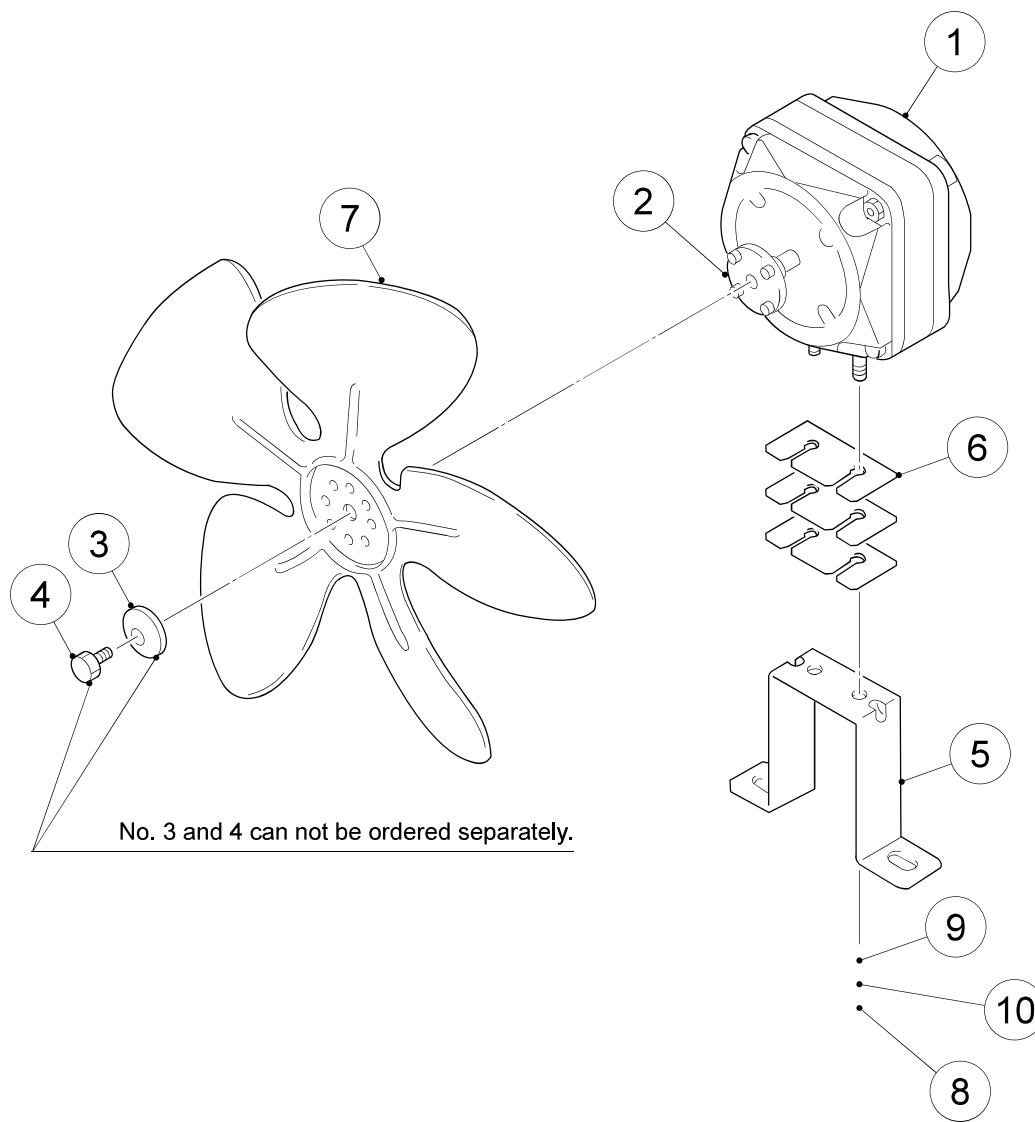

FM-170EE-HC, FM-170EE-HCN
FM-170EE-50-HC,
FM-170EE-50-HCN

N. EVAPORATOR ASSY

(K-1) and later

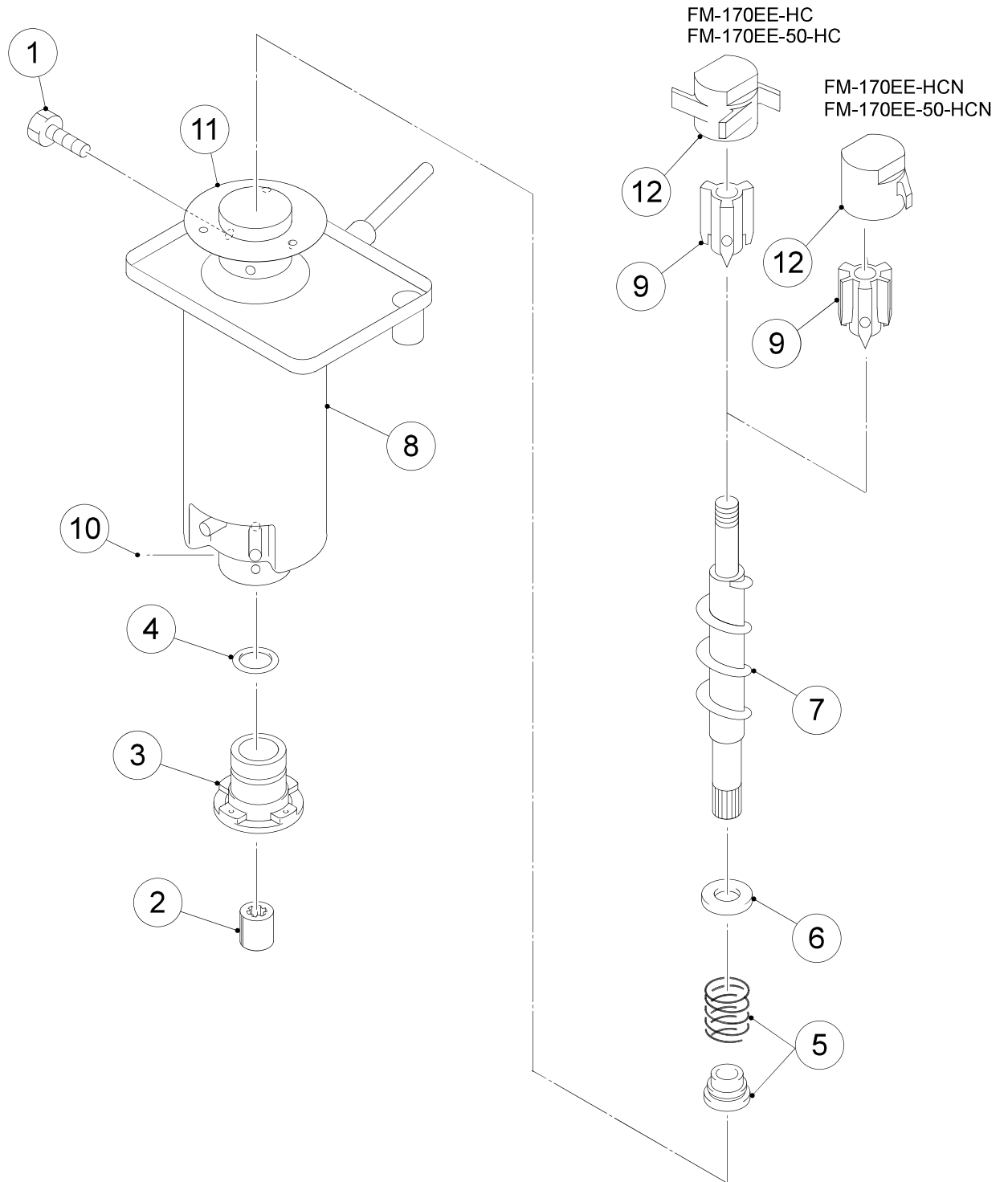

HE

MODEL: FM-170EE-HC(N) FM-170EE-50-HC(N)		TITLE: N. EVAPORATOR ASSY					
INDEX NO.	DESCRIPTION	MATERIAL OR MODEL NUMBER	PART NUMBER	REQ'D NUMBER			
				K-1			
1	SEALBOLT-M8		P01768-01	3			
2	COUPLING-SPLINE ASSY		418316-01	1			
3	HOUSING		206013G05	1			
4	O LING		7616-G040	1			
5	MECHANICAL SEAL		432491-01	1			
6	RING(B)		432494-01	1			
7	AUGER		361013G01	1			
8	EVAPORATOR		258927G01	1			
9	EXTRUDING HEAD-45F	FM-170EE-HC FM-170EE-50-HC	327140G01	1			
	EXTRUDING HEAD-45N	FM-170EE-HCN FM-170EE-50-HCN	327141G01	1			
10	SCREW		P01718-01	4			
11	FLANGE/45		464843-01	1			
12	4CUTTER	FM-170EE-HC FM-170EE-50-HC	427137-01	1			
	CUTTER	FM-170EE-HCN FM-170EE-50-HCN	440905-01	1			

FM-170EE-HC, FM-170EE-HCN

FM-170EE-50-HC,

FM-170EE-50-HCN

P. ACCESSORIES

(K-1) and later

